

ARCA™

TOOL STORAGE





TOOL STORAGE

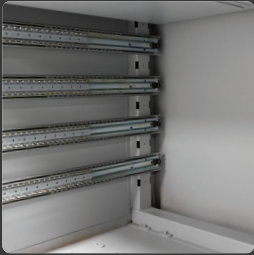

DUAL ROLL CAGE CONSTRUCTION

- Two Cages instead of the 3 in PLATINUM™
- No "Double Wall" used in ARCA™
- Slide piercings are direct into Roll Cage
- Roll Cage construction helps keep the box square from the beginning of the manufacturing process, and creates the most durable box possible. **We are the only Manufacturer that uses Roll Cage Construction**

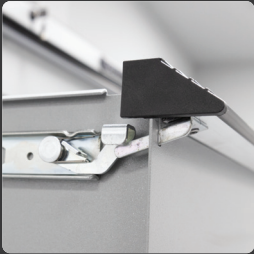

ACCURIDE SLIDES (230lb. Rating)

- Top of the line slides sourced in North America
- Integrated TLC+ into the Slides (Patented by Cornwell)
- Double Slides on Wide Bank Drawers only
- More Ball Bearings
- Operates smoothly under a load and reduces drawer droop when the drawer is at full extension. Latching works well even if the box is on an uneven floor



LOCK MECHANISM

- Mounted to the Roll Cage like PLATINUM™. Not Mounted to the back wall like PRO SERIES®
- Roll Cage mounted locking system is not influenced by warping or oil canning of the back wall. Drawers lock consistently.
- Key lock can be upgraded to an Electronic Lock in the field



6" x 2" CASTERS

- Glass Reinforced Casters
- More durable, lasts longer, and they are better for the environment

EXCLUSIVE PAINT FORMULATIONS



- Textured Mid-Gloss Finish
- Unique formulation that contains metal flake and interference pigments not seen in our industry before
- Easy to clean up - stands up to dirt, grease and finger prints



ARCA™ 57" 8-Drawer Double Bank Roller Cabinet in Ignition Orange



STANDARD COLORS

RE	LY	TB	VP	SM	ST	SH
IGNITION ORANGE	LIGHTNING YELLOW	TORCH BLUE	VAPOR	SMOKE	STORM	SHADOW

*Printed colors may differ from actual color due to variations in the printing process.

57"



57" 8-Drawer Double Bank Cabinet

WIDTH	DEPTH	HEIGHT	DRAWER COUNT	SQUARE CAPACITY	CUBIC CAPACITY	UNIT WEIGHT
57"	25.2"	44.7"	8	5,931 sq.-in.	32,906 cu-in.	485 lbs.

DRAWER CONFIGURATION

55" W x 6" H	
55" W x 6" H	
34" W x 4" H	19.5" W x 8" H Powered Drawer
34" W x 4" H	
34" W x 4" H	19.5" W x 10" H
34" W x 6" H	

TEXTURED MATTE PAINT

- CTSASR578KRE | Ignition Orange
- CTSASR578KLY | Lightning Yellow
- CTSASR578KTB | Torch Blue
- CTSASR578KVP | Vapor
- CTSASR578KSM | Smoke
- CTSASR578KST | Storm
- CTSASR578KSH | Shadow

79"



79" 13-Drawer Triple Bank Cabinet

WIDTH	DEPTH	HEIGHT	DRAWER COUNT	SQUARE CAPACITY	CUBIC CAPACITY	UNIT WEIGHT
79"	25.2"	44.7"	13	8,065 sq.-in.	45,651 cu-in.	745 lbs.

DRAWER CONFIGURATION

19.5" W x 6" H	55" W x 6" H	
19.5" W x 6" H	55" W x 6" H	
19.5" W x 4" H	34" W x 4" H	19.5" W x 8" H Powered Drawer
19.5" W x 4" H	34" W x 4" H	
19.5" W x 10" H	34" W x 4" H	19.5" W x 10" H
	34" W x 6" H	

TEXTURED MATTE PAINT

- CTSASR7913KRE | Ignition Orange
- CTSASR7913KLY | Lightning Yellow
- CTSASR7913KTB | Torch Blue
- CTSASR7913KVP | Vapor
- CTSASR7913KSM | Smoke
- CTSASR7913KST | Storm
- CTSASR7913KSH | Shadow

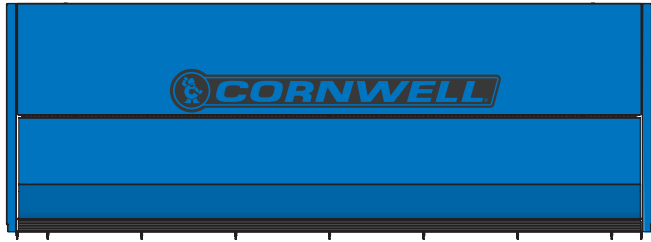

57" & 79" Canopies

- Canopy and Roll Cabinet combined height will be 72"
- Articulated door
- Extruded aluminum handle for door
- Integrated power
- Motion sensitive light

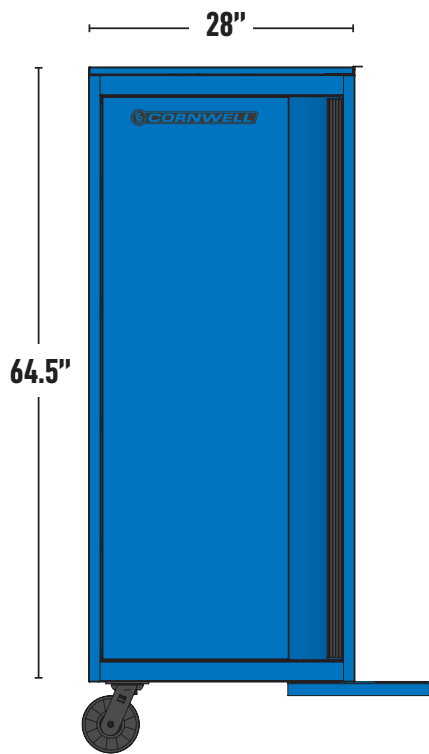
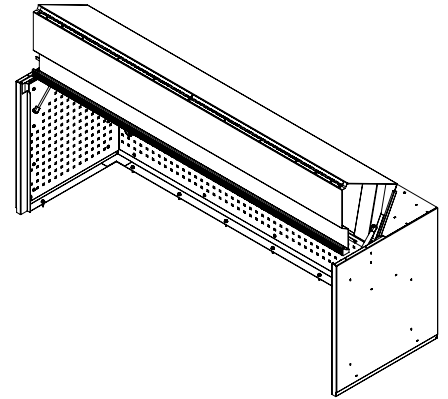

Lockers

- Sized for ARCA™
- Includes 2 swivel casters

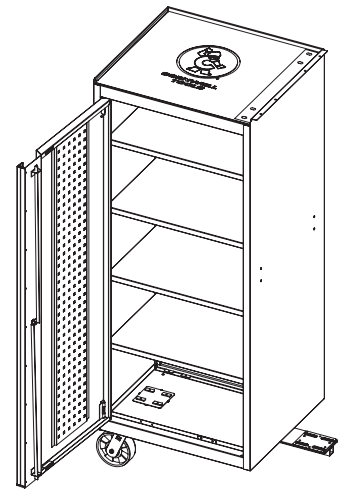

Other Accessories

- Covers
- Color Trim Kits
- Electronic Lock option
- Magnetic Power Bar



ARCA™
TOOL STORAGE



PLATINUM™
TOOL STORAGE

VS

57" or 79"

WIDTHS

56" or 84"

25"

DEPTH

30"

44"

HEIGHT

47"

Single-Slide: 230 lbs.

SLIDE CAPACITY

Single-Slide: 260 lbs.

Accuride, North America

SLIDES

Pacific Rim

6" x 2"

CASTERS

6" x 2" spring-loaded

Stamped Rubber Mat

WORK SURFACE

Powder Coated Matte Black Steel

Dual Roll Cage

**ROLL CAGE
CONSTRUCTION**

Triple Roll Cage

Key
(can upgrade to an Electronic)

LOCK STYLE

Electronic

